

CUSTOMER FUSE 16 Amp(C-type)
 CABLE 4 X 2,5mm²(max. dis 100metre)

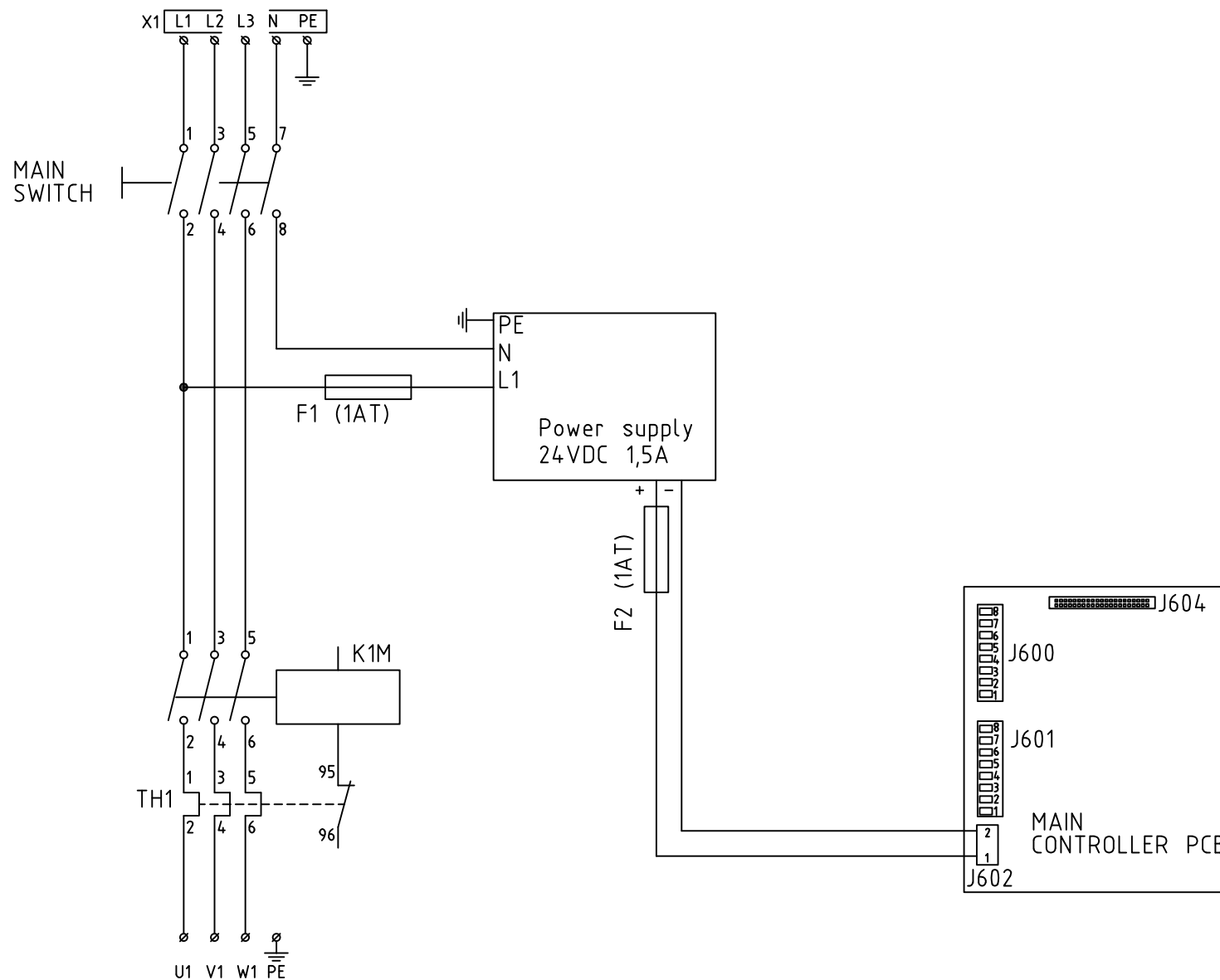

Ferlin

Rudolf Dieselstraat 15A
 7442 DR
 Nijverdal
 Netherlands
 tel. 0548-745370

PROJECT:
 Ferlin MOVAC Easy
 SUBJECT:
 MAIN DIAGRAM

DRAWN BY: N. Vogelzang
 DATE: 25-5-2023
 PROJECTNO.
 PAGE: 1 OF: 3

DRAWING NUMBER:
 HLCPS.0002
 HLCPS.0003
 HLCPS.0004
 REVISION:
 25-5-2023

A4

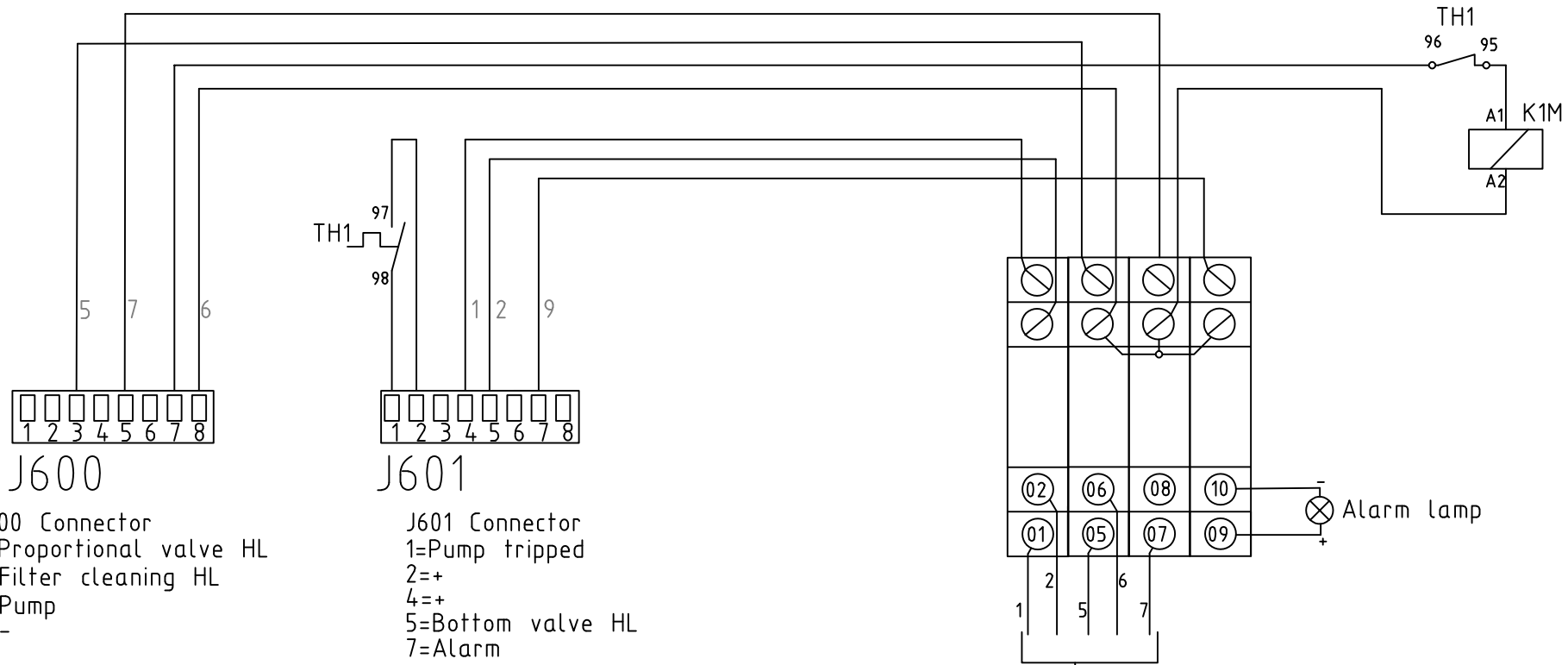

J600 Connector
 3=Proportional valve HL
 5=Filter cleaning HL
 7=Pump
 8=-

J601 Connector
 1=Pump tripped
 2=+
 4=+
 5=Bottom valve HL
 7=Alarm

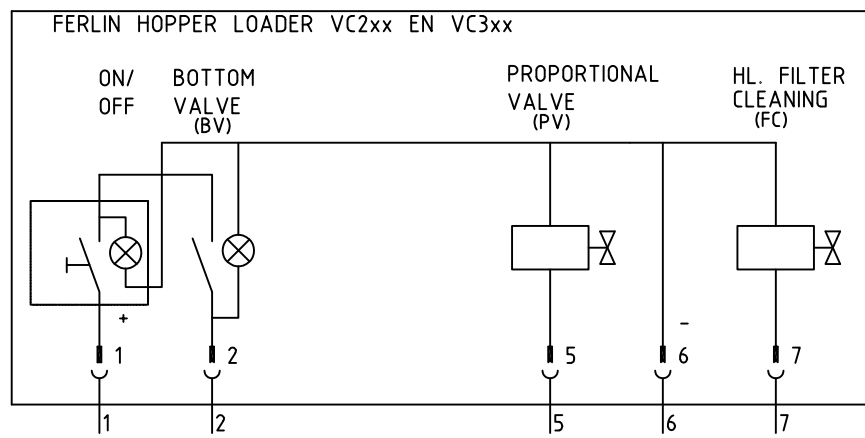

17				
16				
15				
14				
13				
12				
11				
10				
9				
8				
7	1	24VDC POWER SUPPLY	HDR-30-24	HA.00908
6	1	ALARM LAMP	LP4XMV/2	01E40.80200
5	1	MEMBRANE SWITCH FOIL	3.02.002	04E30.02002
4	1	MAIN PCB	5.07.041	04E30.07041
3	1	MOTOR PROTECTION TH1	ZB12-4 2.4-4A	01E31.68440
2	1	MOTOR REALAY K1M	DILEM 12-10	01E31.67688
1	1	MAIN SWITCH	TO-2-8900	01E31.67400
POS.	QUANTITY	PART DESCRIPTION	TYPE	PART NUMBER

Ferlin
Rudolf Dieselstraat 15A
7442 DR
Nijverdal
Netherlands
tel. 0548-745370

PROJECT:
 Ferlin MOVAC Easy

SUBJECT:
 BILL OF MATERIALS PLC

DRAWN BY: N. Vogelzang
DATE: 25-5-2023

PROJECTNO.
PAGE: 3 **OF:** 3

DRAWING NUMBER:
 HLCPS.0002
 HLCPS.0003
 HLCPS.0004

REVISION:
 25-5-2023

A4